

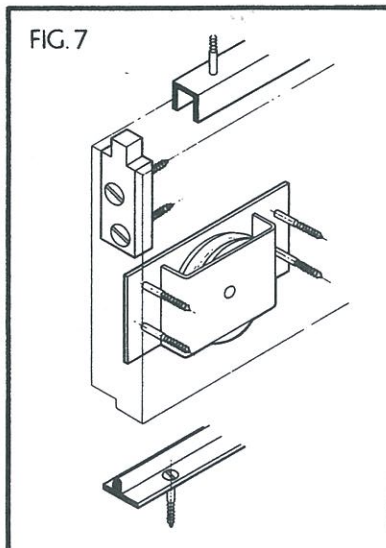

JASON

Maximum weight of door 25kg (50lb)

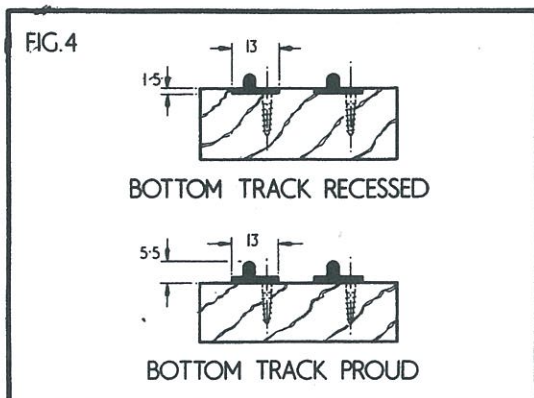
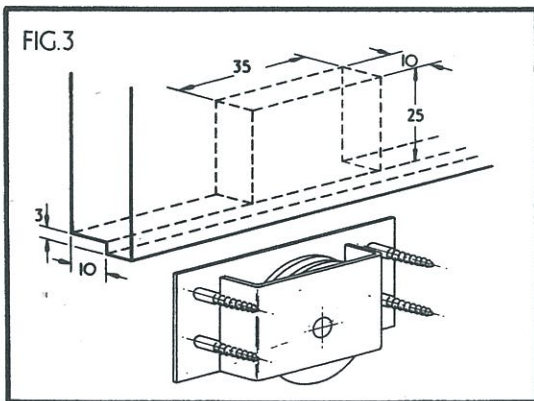
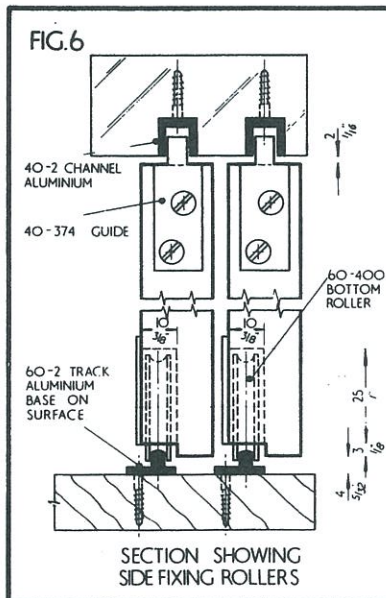
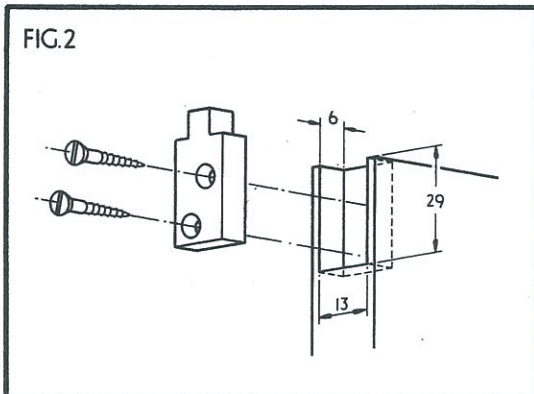
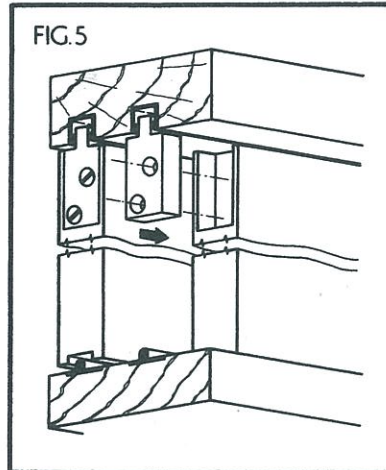
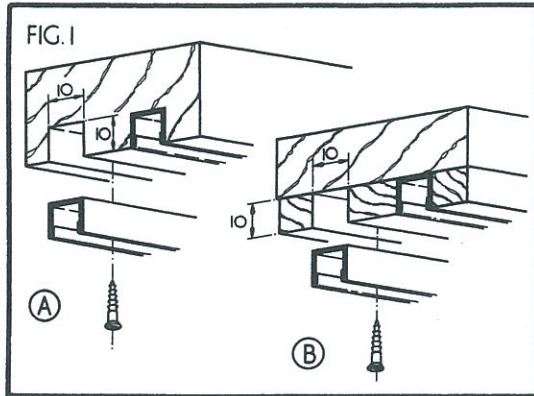

1. Completely read these instructions before commencing to install the gear.

2. Groove head timber to suit 40-2 channel, size 10 x 10mm (3/8" x 3/8"). Cut channel to length and fix with no. 3 x 1/2" long woodscrews – fig 1-A. Alternatively fix timber fillers to head timber leaving 10 x 10mm (3/8" x 3/8") recess to take 40-2 aluminium channel – fig 1-B.

3. Cut out recess in top corner of door to take a 40-374 nylon guide. Repeat other end but do not screw in guides – fig 2.

4. Cut a 3 x 10mm (1/8" x 3/8") rebate, full length of door in bottom inside edge of door. Position rollers close to each edge of door and cut out a tight recess to accommodate the 60-400 side fixing roller housing. Fix with four no. 6 x 3/4" long woodscrews – fig 3.

5. Cut 60-2 aluminium bottom track to length. Track can be recessed into bottom timber or sit proud on top. Fix with no. 3 x 1/2" long woodscrews – fig 4.

6. Offer door onto track, slide 40-374 nylon guides into top channel and screw into cut outs in top corner of door with two no. 6 x 3/4" long woodscrews – fig 5.

7. Fix handles and door stops if required.